

**CURTISS -
WRIGHT**

Ground Vehicle Mission Management Systems

Curtiss-Wright Portfolio of COTS Solutions and Capabilities



Trusted. Proven. Leader.

curtisswrightds.com

Ground Vehicle Mission Management Systems

The U.S. Department of Defense (DoD) and its allies are under increasing pressure to be more flexible in the ways they fight a constantly changing enemy.

As threats evolve and technology advances, ground vehicles add and update payloads to accommodate ever-changing mission needs. These payload options may include cameras, sensors, communications, weapons, etc. A mission management system must meet ever-present size, weight, and power (SWaP) limitations while providing the scalability and flexibility to handle all the mission tasks today’s warfighters may encounter.

To rapidly update systems that respond to the latest threats, system integrators must be able to provide shorter timeframes to field new mission management capabilities. That means going from development to deployment as quickly as possible (Figure 1).

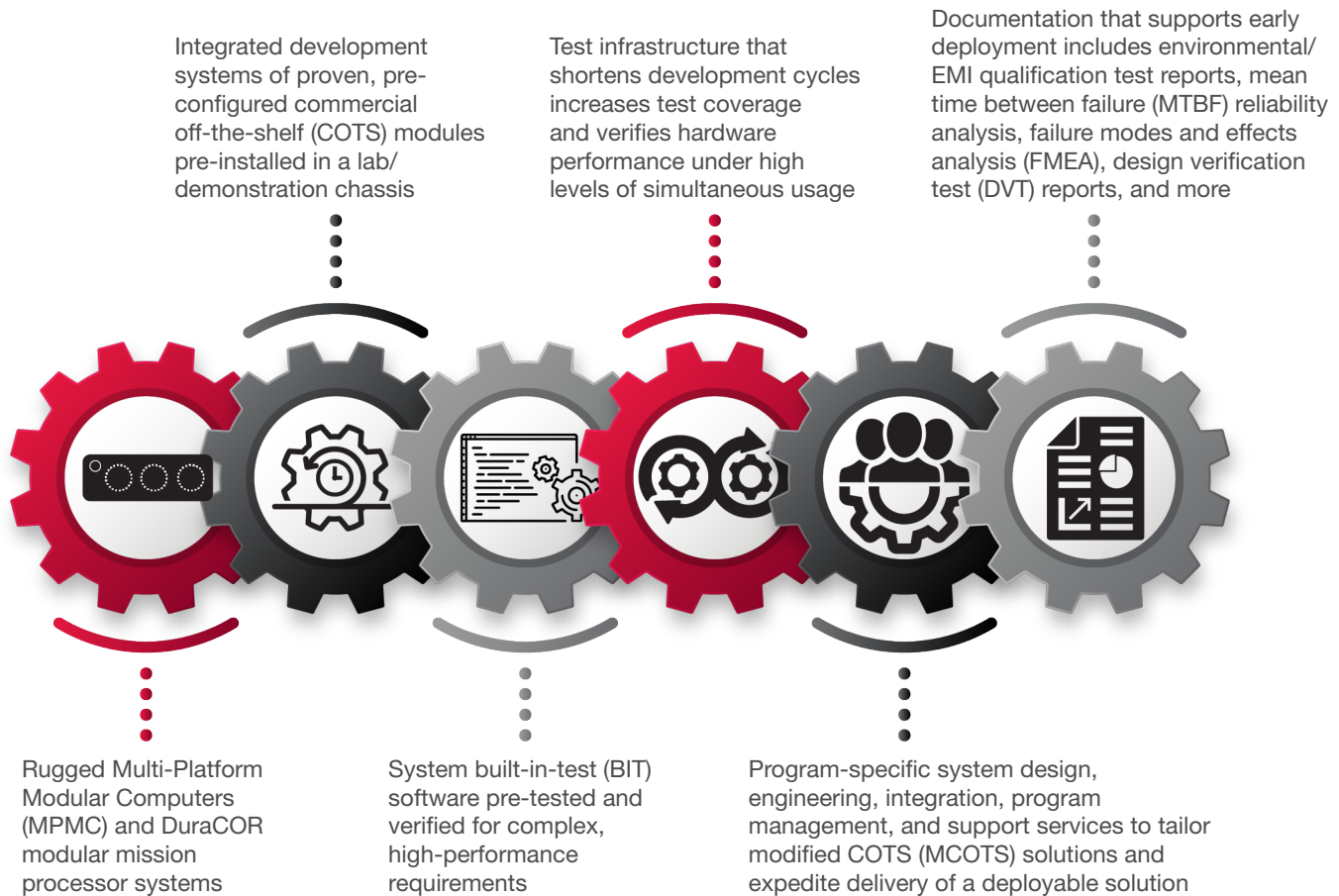

Figure 1: Curtiss-Wright portfolio of COTS solutions and capabilities. These solutions make it easier to deploy field-ready LRUs that provide more functionality than in-house-built systems in a reduced footprint.

Deploy Faster with Completely Integrated Mission Management Systems

Curtiss-Wright is the trusted, proven leader in developing rugged electronic components and systems for aerospace and defense applications. As a technology and integration partner to its customers, we provide a full range of advanced, highly engineered, scalable solutions that adhere to open systems architectures, like 3U VPX, 6U VPX, and small form factor (SFF) solutions.

We support the various DoD initiatives such as C4ISR/EW Modular Open Suite of Standards (CMOSS), Mounted Assured Position, Navigation and Timing (MAPS), Modular Open Radio Frequency Architecture (MORA), Future Airborne Capability Environment (FACE™), Sensor Open System Architecture™ (SOSA) and Vehicle Integration for C4ISR/ EW Interoperability (VICTORY).

When our customers' programs require line replaceable units (LRU) with demanding size, weight, and power (SWaP) constraints and need to get from development to deployment as quickly as possible, Curtiss-Wright delivers fully developed COTS modular mission systems that enable our customers to deploy faster.

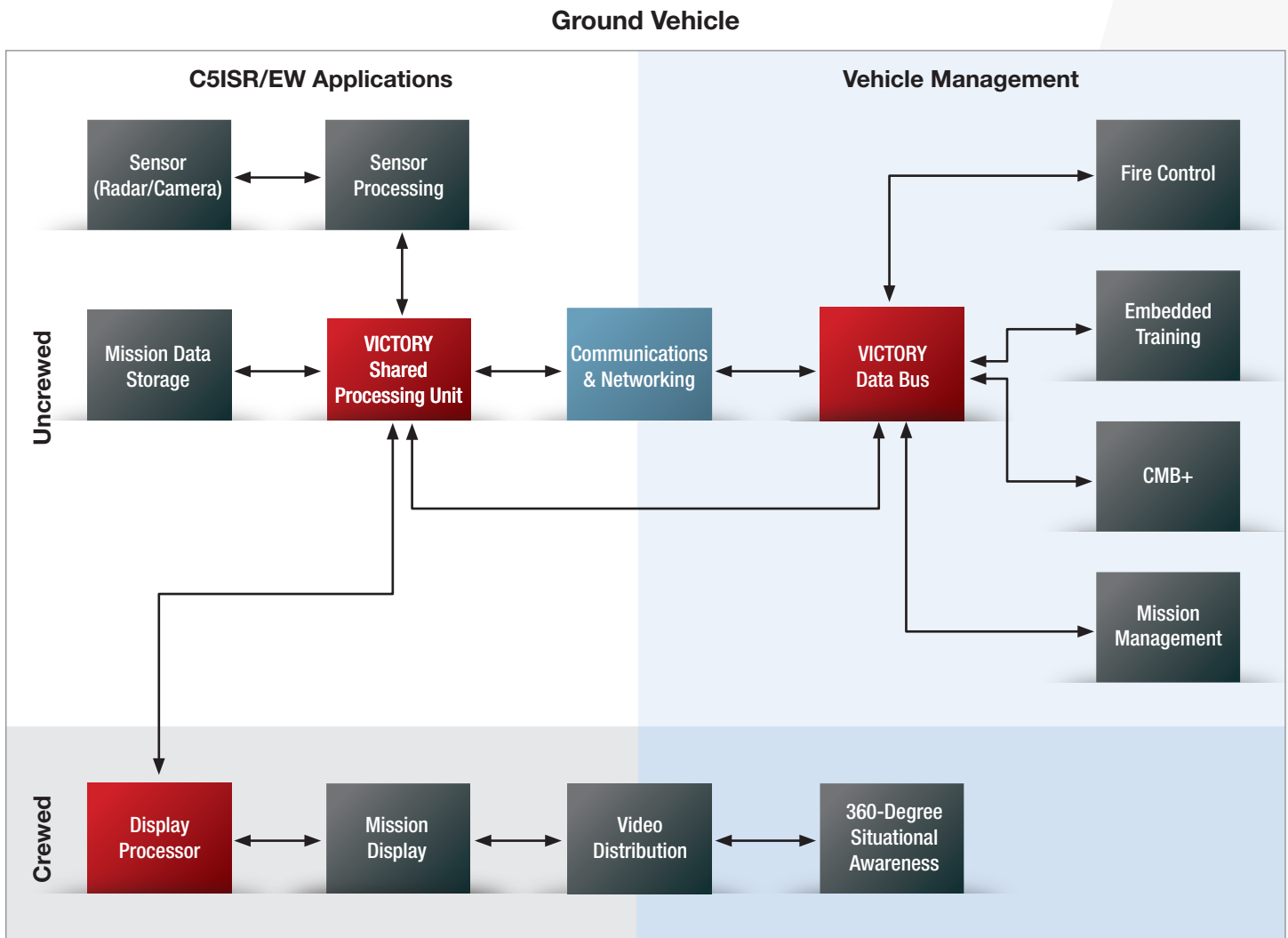

Figure 2: Mission management systems in C5ISR/EW and vehicle management applications

Proven COTS Technology Building Block

Our mission management systems are built on a wide range of proven COTS building blocks, creating a quick turn infrastructure that customers can rely on. Our system architects work with customers to mix and match system capabilities using our wide range of COTS boards and packaging options to create a completely integrated solution that meets their program needs. Our multifunction subsystems provide higher performance levels, reduce power consumption, and minimize the number of LRUs required — all critical attributes for rugged systems deployed in space-constrained environments.

Curtiss-Wright uniquely supports the widest range of critical technologies required by today's most demanding military applications. Through leadership in standards bodies, research, and adoption of new technologies, Curtiss-Wright has the experience and expertise to mitigate challenges in:

- Packaging for ruggedization in ground vehicle applications, including compliance with ATPD-2404 standards, thermal management, ruggedization, signal integrity optimization, and structural analysis
- Open architectures, including OpenVPX, VME, CMOSS, MORA, SOSA™, VICTORY V1.9, FACE, FMC, XMC, COMExpress, SMARC, PCIe104, and Mini-PCIe
- Reliability of electronics and qualification to MIL-STD-810, MIL-STD-461, MIL-STD-1275, MIL-STD-704, DO-160, and other standards
- Trusted and secure computing, from trusted processes and suppliers to cybersecurity data and program protection
- High technology readiness level (TRL) systems with roadmaps for new technology insertion and obsolescence mitigation

Leverage Pre-Configured Ultra-SFF Designs

To decrease development time, our portfolio of systems also includes ultra-SFF COTS systems that can be quickly and easily adapted to platform-specific requirements based on the integration of open architecture add-on cards.

Curtiss-Wright's Parvus® DuraCOR® rugged mission computers feature modular, expandable designs, powerful graphics and data processing capabilities, and reliable mechanical robustness in a miniature form factor. Curtiss-Wright has engineered its DuraCOR product family to address size, weight, power, and cost (SWaP-C) requirements, enabling our customers to deploy a fully functional, environmentally hardened LRU — tailored to specific needs — in weeks.

These MIL-STD-qualified mission processors have been field-proven in C5ISR technology refresh and platform upgrade programs under thermal, shock, and vibration extremes in uncrewed and crewed aircraft, ground vehicles, and maritime platforms. Each unit features electrical/mechanical I/O expansion capabilities that rapidly integrate payload-specific I/O interfaces for avionics, vetronics, situational awareness, and other applications.

Curtiss-Wright provides application engineering services to extend base system computing functionality for these SFF systems, adding in application-specific I/O and communications cards—typically with minimal NRE fees and competitive delivery schedules. With turnkey, pre-qualified subsystems tailored by the factory, DuraCOR customers reduce technical risk and program management overhead while maximizing the use of open architecture COTS building blocks.

Examples of Pre-Validated Mission Management Systems

Parvus DuraCOR 313

The Parvus DuraCOR 313 is an ultra-small form factor (USFF) rugged embedded computer based on a low-power, quad-core Intel® Atom® x6400E Series processor equipped with unparalleled modularity for add-on I/O cards and data storage in a fanless IP67-rated miniature design.

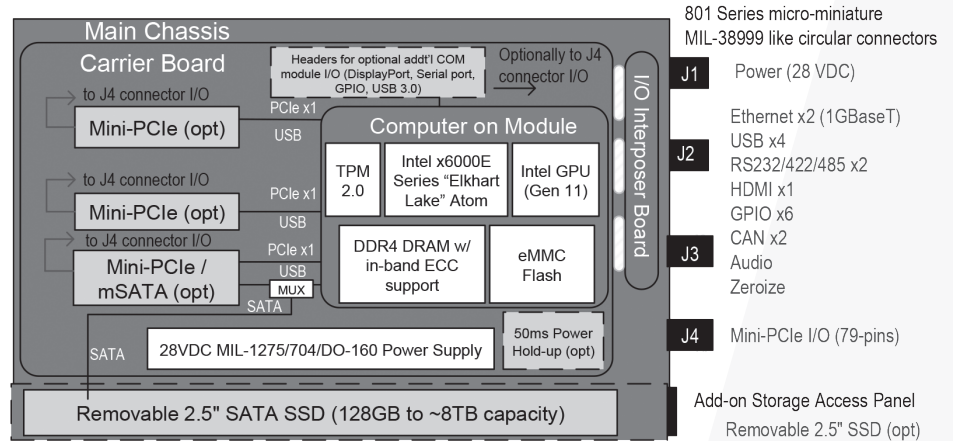

Figure 3: DuraCOR 313 block diagram

Parvus DuraCOR 8043

The Parvus DuraCOR 8043 is a small form factor COTS modular mission computer based on a quad-core (8-thread), 6th gen "Skylake" Intel Xeon® E3 v5 processor combining powerful graphics and multi-core Xeon processing with ultra-reliable modular, mechanical robustness in a rugged chassis optimized for military and aerospace vehicle and aircraft platforms.

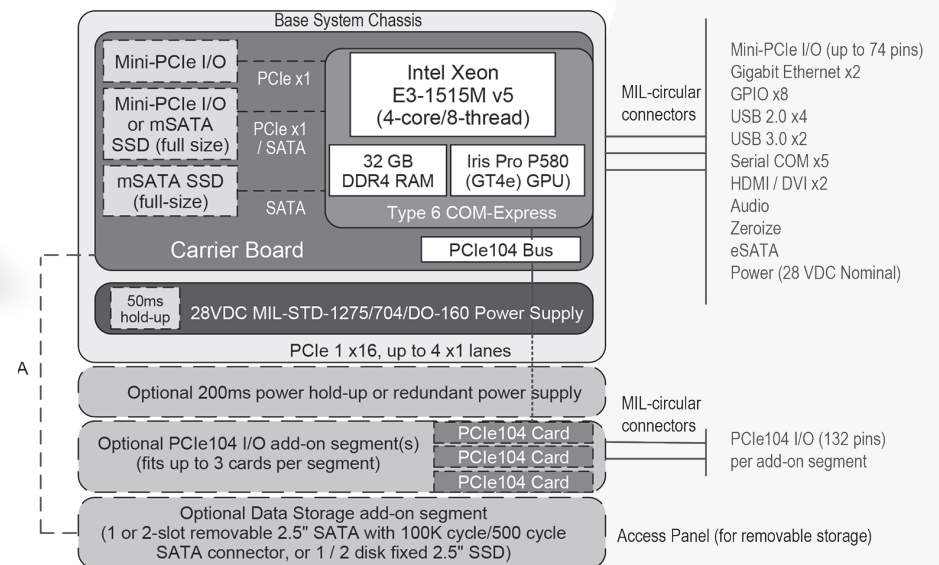

Figure 4: DuraCOR 8043 modular mission computer

MPMC-9020

The MPMC-9020 is a compact, lightweight, yet rugged subsystem that operates in harsh environments. Equipped with a built-in controller and power supply, the MPMC-9020 supports two PMC/XMC mezzanine cards without requiring an additional single board computer (SBC) to drive the system.

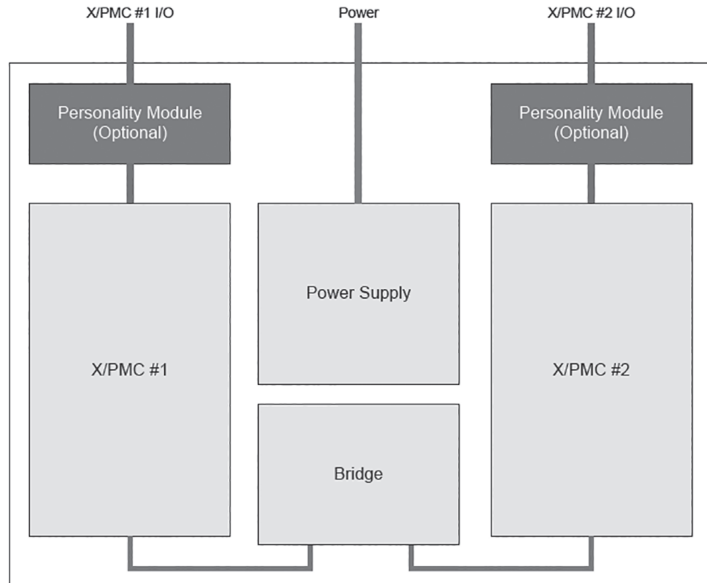
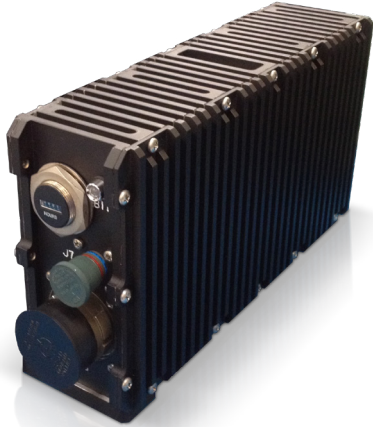

Figure 5: 2-slot 3U VPX Power Architecture-based MPMC mission computer

MPMC-935x

The Curtiss-Wright MPMC-935x family of 3U 5-slot systems are leading-edge, flexible, and rugged processing systems readily configured to meet specific military and aerospace program requirements. Their ruggedized modular construction enables them to be used in lab development systems and using the same hardware deployed in the harshest avionics environments.

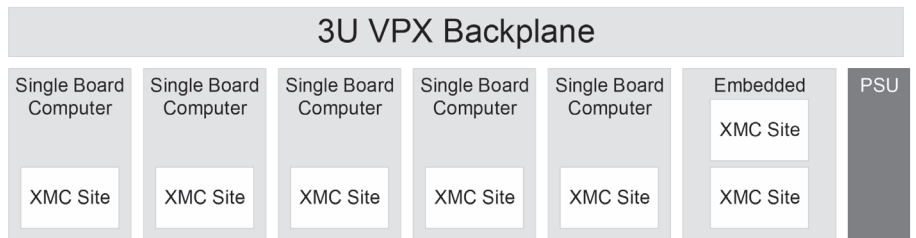

Figure 6: MPMC-935x block diagram

PacStar Communications Solutions

Combining modular networking equipment and our IQ-Core® Software for unified network communications management, our tactical communications solutions enable enhanced warfighter situational awareness. Curtiss-Wright's battlefield network management portfolio includes SFF communications systems and PacStar® Commercial Solutions for Classified (CSfC) solutions.



Modular Devices

Tactical, rugged, low-SWaP networking and communications hardware, designed using a customer-centric approach

- Snap-together design enables quick expansion with other PacStar 400-Series products and quick reconfiguration of modules and chassis
- Extensively tested to MIL-STD-810 by independent labs
- Integrated power supplies that run on tactical radio batteries, wide range DC input and worldwide AC input
- Continuous runtime with hot-swappable batteries
- Regulated 12 VDC output supports powering KG-250X/XS or other accessories
- Best-in-class SWaP, typical module weight 2.5 lbs



Integrated Solutions

Tactical and expeditionary solutions based on PacStar 400-Series, ready to meet mission requirements

- PacStar Integrated Solutions include a variety of CSfC systems
- Can be combined with IQ-Core Software and a vast array of partner technologies, as needed
- COTS-based
- Modular, turnkey tactical, and expeditionary
- Best-in-class SWaP



IQ-Core Software

Intuitive communications management that eases system management complexity

- Network communications management technology optimized for the unique challenges faced by tactical units
- Provides a unified “single pane of glass” view for network monitoring and diagnostics, giving operators real-time situational awareness (SA)
- Tailorable to the user level and includes role-based access control, an intuitive GUI, command line access, and advanced automation technology in a single solution, enabling users to complete tasks faster with fewer errors
- Reduces set-up time, allowing communications to adapt to rapidly-changing circumstances and improve mobility

Curtiss-Wright Understands Your System Requirements

With decades of experience providing rugged computing and avionics solutions for the aerospace and defense industries, Curtiss-Wright has developed systems currently deployed in ground combat vehicles, tactical wheeled vehicles, and precision fire systems.



Learn More

Curtiss-Wright White Papers

[Ultra-Small Form Factor Mission Systems](#)

[Eliminating Design Risk from the System Integration Equation](#)

[Reducing Development Cycles for 3U VPX Systems](#)

[Small Form Factor \(SFF\) Mission System Modularity Enables Choice of Distributed or Consolidated Architectures](#)

[Leveraging Modular Open System Architecture for Modified COTS](#)

Curtiss-Wright Case Studies

[Rugged Router and Switch Combo Provides Secure Networking for Ground Vehicle's Warfare System](#)

[Enabling VICTORY Data Bus Network for an Armored Ground Vehicle](#)

Product Information

[Parvus DuraCOR Mission Computers](#)

[3U MPMC Systems](#)

[6U MPMC Systems](#)

[Program Specific Systems](#)

Contact Us

 curtisswrightds.com/contact

 ds@curtisswright.com

curtisswrightds.com