

# Grounding and shielding of the Axon and Acra KAM-500

TEC/NOT/063

**CURTISS -  
WRIGHT**

This technical note describes the recommendations for grounding and cable shielding of the Acra KAM-500. This information is also applicable to Axon products.

This paper discusses the following topics:

- “36.1 Axon/KAM-500 isolated grounds” on page 1
- “36.2 Axon/KAM-500 chassis bonding and grounding” on page 2
- “36.3 Validating grounding” on page 3
- “36.4 Cables and shielding” on page 3
- “36.5 Incorrect configurations” on page 5
- “36.6 Grounding for multiple Axon/KAM-500 chassis” on page 5
- “36.7 Co-axial Radio Frequency interfaces” on page 6
- “36.8 Glossary” on page 7
- “36.9 Related documentation” on page 9
- “36.10 References” on page 9

## 36.1 Axon/KAM-500 isolated grounds

The Axon/KAM-500 has the following three grounds:

- **GND**: Axon/KAM-500 internal electrical ground
- **CHASSIS**: Axon/KAM-500 external shielding ground
- **POWER(-)**: 28V return

---

**NOTE:** All three grounds are isolated from one another inside the Axon model A and KAM-500 chassis. In the Axon model B chassis, GND and CHASSIS are joined with an internal link. An example part number for Axon model A is AXN/CHS/09U and for model B is AXN/CHS/09U/B.

### 36.1.1 GND

GND is the internal zero volt line that all Axon/KAM-500 modules reference. All input and output signals on Axon and KAM-500 modules are referenced to this potential. The GND reference signal is normally taken out to the connector on the top of each Axon and KAM-500 module and is usually pin 51. The GND connection is also available on the Axon/KAM-500 Power Supply Unit (PSU) connectors. The Axon model B PSU connector brings out GND and CHASSIS on the same pin.

### 36.1.2 CHASSIS

CHASSIS is the signal name for a connection to the physical Axon/KAM-500 chassis (metal work). CHASSIS is also known as mechanical, shielding, or safety ground. The Axon and KAM-500 top blocks, connector frames, and the ground mounting bolt on the PSU are at CHASSIS potential. The PSU connector backshell will be at CHASSIS potential. Most KAM-500 PSU connectors also have a CHASSIS pin.

The standard connector on Axon and KAM-500 modules has a pin connected to CHASSIS (this pin is typically pin 52 of the top-block connector). The connector frame and jackposts are also at CHASSIS potential, which means that the backshell frame is connected to CHASSIS via the top-block connector as shown in the following figure. This is especially useful when connecting cable shields.

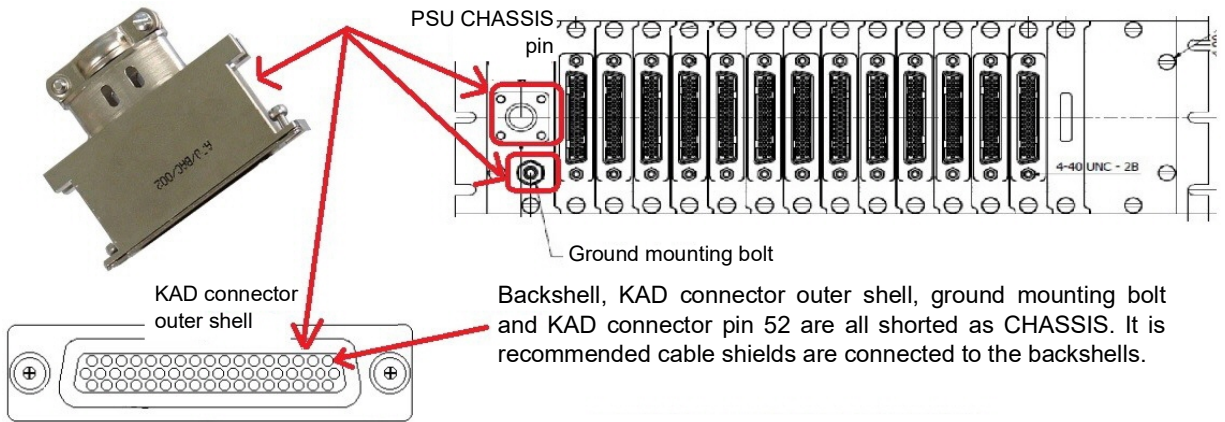

Figure 36-1: Chassis connections on KAM-500

### 36.1.3 POWER(-)

POWER(-) is the return line for the 28V Axon/KAM-500 power supply. The POWER(-) pin is not connected to the CHASSIS line nor GND line within the Axon/KAM-500.

To improve EMC, it is recommended to be run as a twisted pair with the 28V supply line.

POWER(-) must be referenced to the external star point (airframe, or chassis). This can be done at the source of supply (for example battery or generator).

Both Axon and KAM-500 PSU are compliant with the EMC standards listed in the *Environmental Qualification Handbook for Axon Products* and *Environmental Qualification Handbook (Acra KAM-500)* respectively without the need for shielding on the power lines.

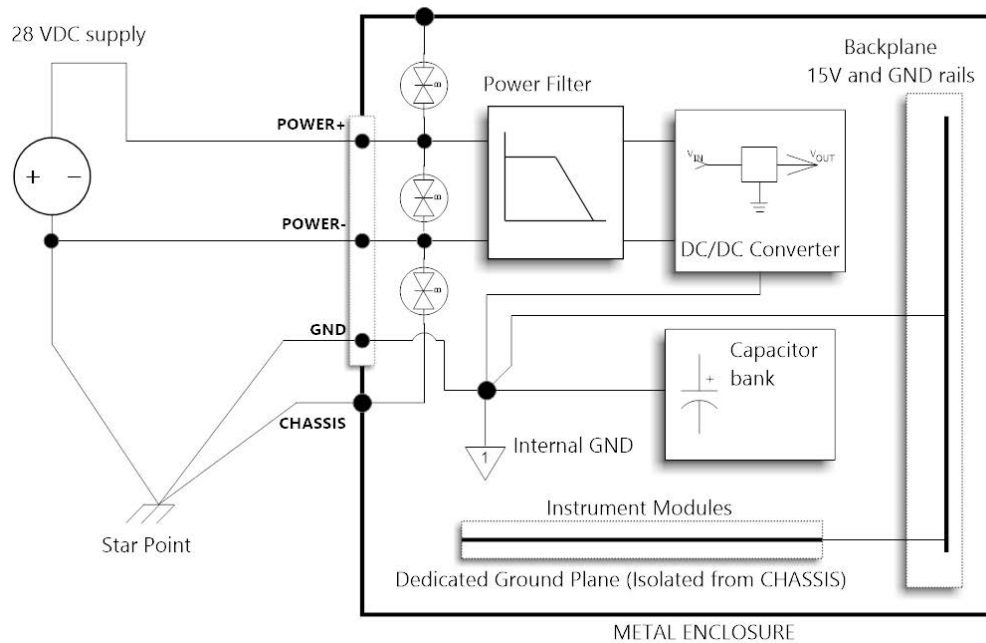

Figure 36-2: Power supply and backplane connections for Axon (KAM-500 is similar)

## 36.2 Axon/KAM-500 chassis bonding and grounding

As a general recommendation, each isolated ground signal should be connected to the main star point on the aircraft or vehicle using a low impedance connection. Hence the GND pins on the Axon and KAM-500 PSU connector, the CHASSIS pin on the PSU connector (if available) and the POWER (-) pin on the PSU connector should be connected directly to the star point.

The following figure shows an example of connecting a star point to POWER(-), GND, and CHASSIS. It shows the ideal or lab condition grounding scheme, however actual aircraft applications may differ from this grounding scheme due to installation issues such as the distance between the power supply, the Axon/KAM-500, and the airframe, which may act as CHASSIS.

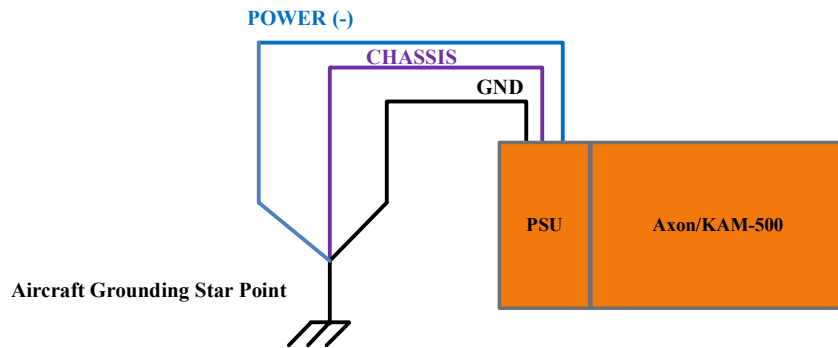

Figure 36-3: Axon/KAM-500 ideal grounding scheme

Because POWER(-) is carrying return current, it must not be combined with GND or CHASSIS ahead of the star point. Shorter cables are better because they have lower impedance and less chance of Radio Frequency (RF) noise pickup.

For the CHASSIS connection to the star point, it is recommended to use the ground mounting bolt on the PSU with a short braided cable instead of the CHASSIS pin. Braided cable has lower high-frequency impedance than single wires.

The chassis mounting bolts may be used for bonding, if they make good electrical contact (< 50 mΩ) with both the mount and the Axon/KAM-500 chassis. The unpainted base of the Axon is also very suitable for chassis bonding.

To keep GND from floating relative to CHASSIS, they should be joined together. Join at only one point to prevent ground loops. A convenient place, that does not overly expose the internal GND to the external environment, is inside the PSU connector backshell using the GND pin. The Axon model B joins GND and CHASSIS at one point internally.

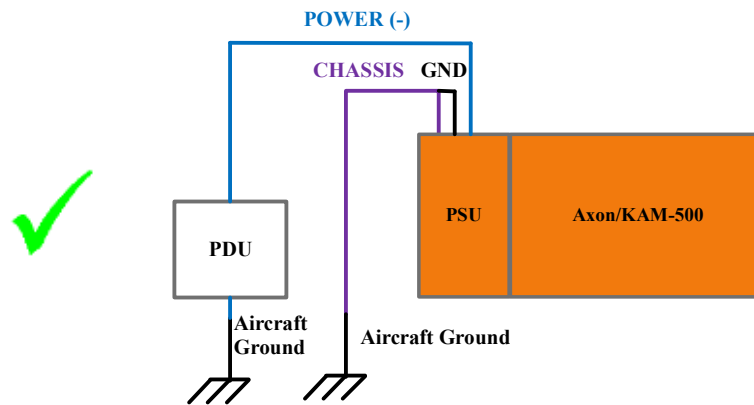

Figure 36-4: GND referenced to CHASSIS

### 36.3 Validating grounding

After connecting the grounds, measure the resistance between each GND point, CHASSIS point and POWER (-) on each Axon/KAM-500 to the star point. The resistance should be below 50 mΩ. Ground validation on aircraft is critical for data measuring equipment especially in distributed systems.

### 36.4 Cables and shielding

The intention of using a shielded cable is to create a continuous conductive shield envelope (Faraday cage) for the signal lines, incorporating the cable shield, cable clamp, backshell, connector, and top-block.

It is recommended to use metal backshells.

All cables should be shielded with the shields connected to the Axon/KAM-500 CHASSIS, through the connector backshells.

Modern standards for high-performance cables always recommend 360° shield termination. (<https://ntrs.nasa.gov/citations/20090033805>)

If the backshells have shield terminations then these should be used, otherwise the backshell cable clamp can be used for the electrical connection if it is clamped directly onto the cable shield braid or ferrule.

An alternative method of connecting a cable shield to an Axon/KAM-500 module is to use a short pig-tail and take this from the cable shield to the CHASSIS pin on the Axon/KAM-500 connector. This method is acceptable but not recommended as it may result in a short length of unscreened signal cable and a discontinuity in the shield envelope. A single wire also has higher RF impedance than a clamped backshell due to its lower cross-sectional area.

In many analog sensor applications, connecting only one end of the shield may give better EMC results, for instance when the predominant noise comes from a difference in the potential between the signal source and the Axon/KAM-500 CHASSIS.

To avoid ground loops, the sensor case and cable shield may have to be insulated from the airframe. For instance, as shown in the following figure, accelerometers may need to be used with insulated bases when mounted on metal airframes to avoid creating a second current path to the Axon/KAM-500 module through the airframe. Another technique is to run a Parallel Earth Conductor close to the cable, to give a lower impedance path than the cable shield between the two points. An example of this could be running the cable alongside well-bonded metal aircraft structural components, or pairing it with its own ground wire.

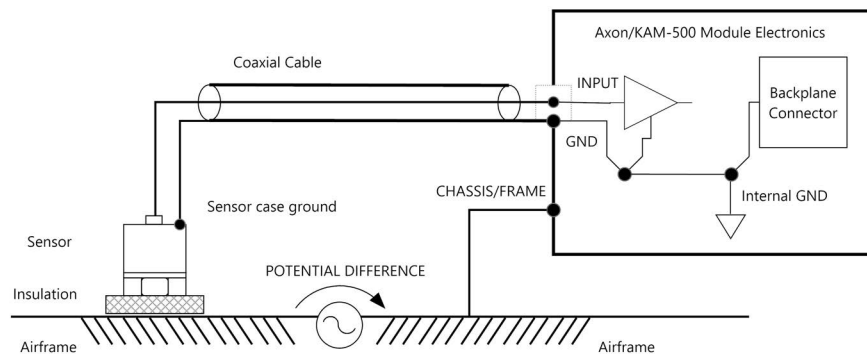

*Figure 36-5: Insulating sensor case and cable shield*

Most high-speed Ethernet or bus monitor cable shields should be connected to CHASSIS at each end of the cable run. The standard cable should be shielded twisted pair. Differential signals should be paired with their other half and single-ended analog signals should be paired with their own ground reference/returns.

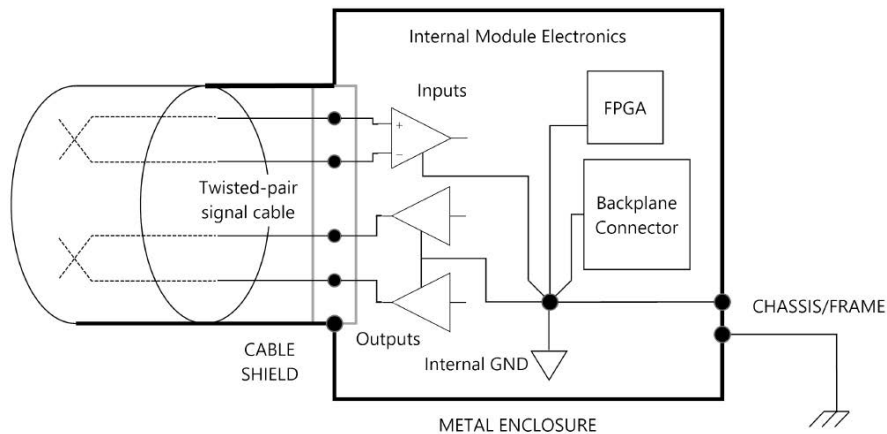

*Figure 36-6: Cable shield and chassis create RF envelope*

When using sensors powered with an isolated external power supply, the ground of the external power should be referenced to Axon/KAM-500 GND. When possible, use KAM-500 internal power supply levels such as  $\pm 12V$  or  $+5V$  (available in KAM/PSU/012 and KAM/PSU/011 power supply units) or excitation modules. Refer to the power supply unit data sheet for voltage levels and maximum current available.

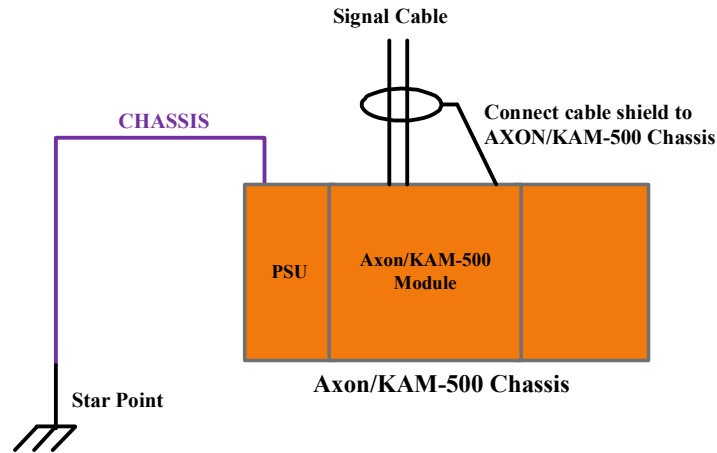

Figure 36-7: Shielding

Curtiss-Wright recommends the use of twisted pairs with an overall foil shield. Wires should ideally be silver plated.

Coaxial cable signals such as a GPS or video are a special case. The cable shield is considered to be chassis potential but internally the signal reference is Axon/KAM-500 GND. For these signals it is necessary to make a link between GND and CHASSIS relatively close to the cable connector. See “36.7 Co-axial Radio Frequency interfaces” on page 6.

### 36.4.1 Transient protection

Where a ground connection is required for transient protection devices, these devices should be connected to Axon/KAM-500 CHASSIS and not the Axon/KAM-500 GND. In this configuration, CHASSIS both shields the Axon/KAM-500 electronics from transients and provides a low impedance path to the article star point for such transients.

## 36.5 Incorrect configurations

### 36.5.1 Incorrect Axon/KAM-500 grounding

POWER(-) must not share a common cable to the star point as shown in the following figure.

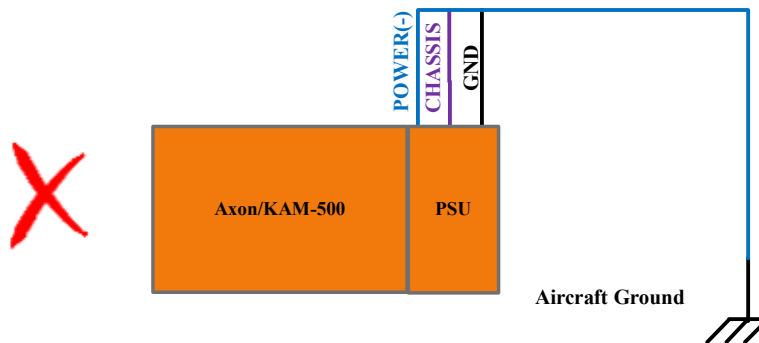

Figure 36-8: Do not use CHASSIS connection as Power Return

## 36.6 Grounding for multiple Axon/KAM-500 chassis

When more than one Axon/KAM-500 is used, each Axon/KAM-500 should be connected to the star point using individual cables. Shared cables should not be used. No two chassis should share common cables for the GND, POWER(-) or CHASSIS signals.

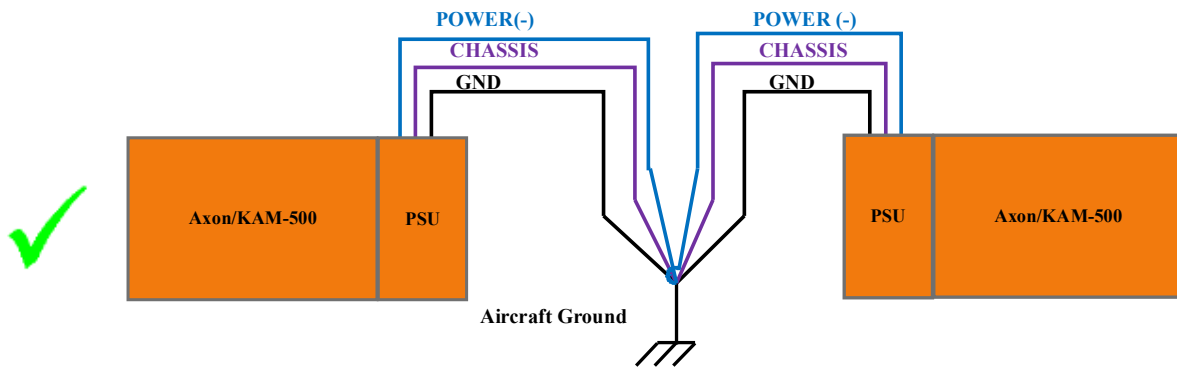

Figure 36-9: Do not share or daisy-chain

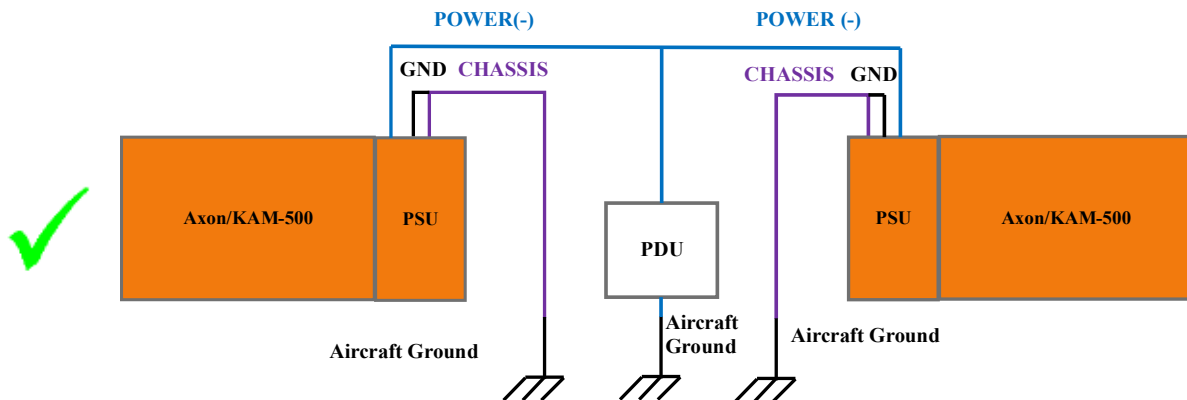

Figure 36-10: How to ground two chassis: Ideally each chassis should have its own connection to the star point

## 36.7 Co-axial Radio Frequency interfaces

When co-axial cable is used to interface an Axon/KAM-500 module to an external antenna (for example GPS) the cable shield behaves as both an RF signal ground and a transient protection ground. That is, any transients are conducted by the cable shield, whilst the cable shield also provides a signal return path to the antenna/transmitter.

### 36.7.1 Axon modules

In Axon RF modules such as the AXN/TCG/401, CHASSIS and GND are connected together in the module itself, since the co-axial cable shield is providing both RF ground and transient protection grounding functions. This introduces the risk of creating ground loops in the aircraft/test article wiring unless care is taken with the wiring design. See the following figure. Ground loop current through the cable shield can also be mitigated with the use of Parallel Earth Conductors, such as running the cable close to metal aircraft structural components.

If a link between CHASSIS and GND is present at the RF module, then ideally these signals should not be linked anywhere else. Otherwise some Ground currents may find a path through the chassis and vice versa. Since CHASSIS and GND are already linked near the PSU in the Axon model B, should this type of issue arise, try moving the RF module close to the PSU to shorten the potential loop.

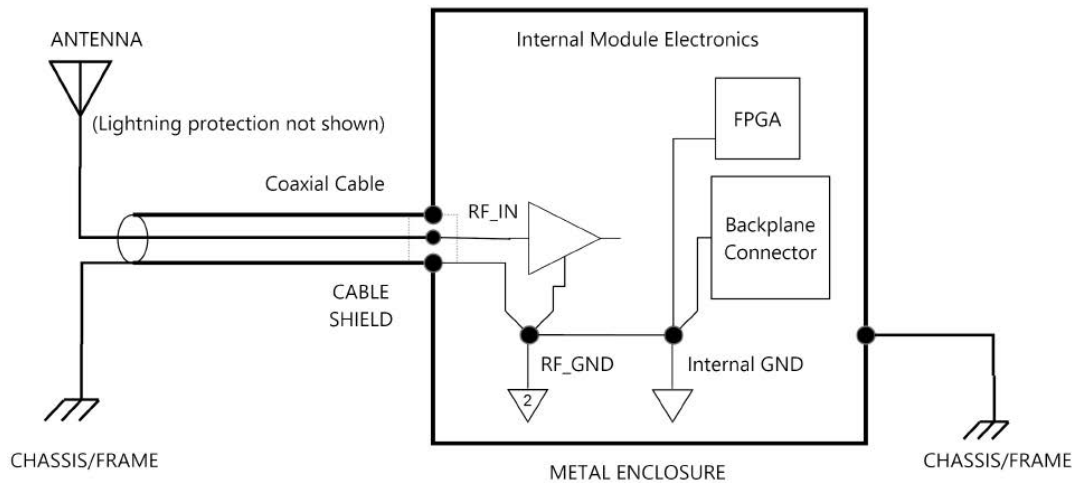

Figure 36-11: Axon grounding with AXN/TCG/xxx module and GPS antenna

### 36.7.2 Acra KAM-500 Modules

In KAM-500 modules with coaxial input signals such as GPS, wireless or video, both CHASSIS and GND must be connected together as close to the module as possible. Since the co-axial cable shield is providing both RF ground and transient protection grounding functions, an electromagnetic loop with the grounding star point will be created if this is not performed, potentially reducing the sensitivity of the GPS receiver and providing an EMI antenna for noise from the KAM-500.

This introduces the risk of creating ground loops in the aircraft/test article wiring unless care is taken with the wiring design. If CHASSIS and GND are connected together near the RF module, this should ideally be the only such connection between CHASSIS and GND.

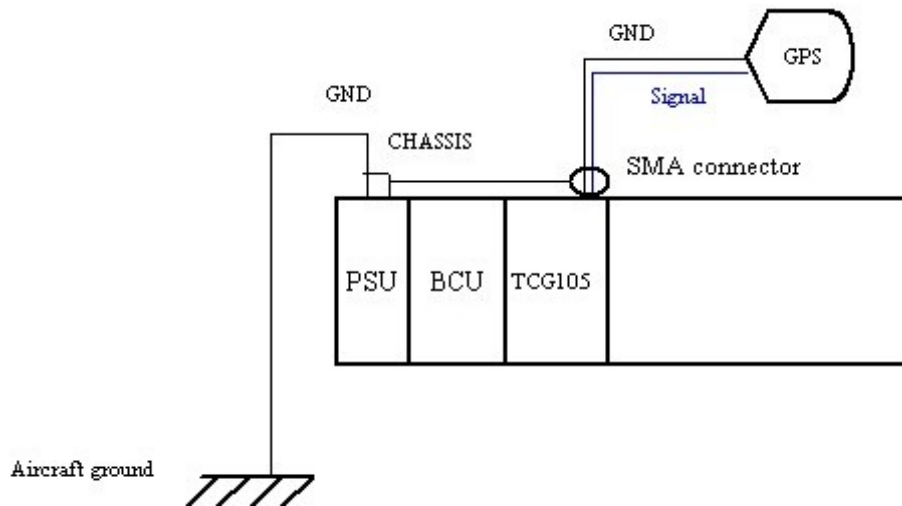

Figure 36-12: KAM-500 grounding with KAD/TCG/10x module and GPS antenna

This technical note does not cover lightning arrestors or other safety devices, which would normally be required for external antennae.

## 36.8 Glossary

### Chassis

The metal enclosure of the Axon/KAM-500. Any element at the same electrical potential as the chassis, such as screws in direct metal-to-metal contact, is said to be at CHASSIS potential.

### Distributed system

Application in which more than one KAM-500 or AXON are synchronized and data from different Data Acquisition Units (DAUs) is being gathered at the same time.

**EMC**

ElectroMagnetic Compatibility

**EMI**

ElectroMagnetic Interference

**Faraday cage**

A conductive enclosure with limited apertures, such that radiated RF energy inside is not detectable outside, and vice versa.

**Frame**

The metal frame of the aircraft external to the Axon/KAM-500, if one exists, or the conductive path to the star point or ground plane provided in lieu of one. The Axon/KAM-500 chassis should be electrically bonded to the frame.

**Ground**

A common reference point for all electrical signals in a circuit.

**Ground loop**

An unwanted current flowing between ground reference points in two separate devices at different ground potentials.

**Lightning arrester**

A lightning arrester (also called lightning diverter) is a device used on electric power systems and telecommunication systems to protect the insulation and conductors of the system from the damaging effects of lightning.

**Loop antenna**

A loop formed by a wire or other conductor that can pick up RF energy, intentionally or not.

**PDU**

Power Distribution Unit

**Shield**

A conductive layer around a cable that encloses signal carrying wires. The shield is used to couple any incoming or outgoing EMI and conduct it to CHASSIS, thus attenuating any interference to the enclosed signal carrying wires and ensuring that any noise from the enclosed signal carrying lines does not adversely affect nearby equipment.

**Star point**

The star point is a common point for all grounds on the aircraft or vehicle. It is the designated reference point for all voltages and signals. (Note: In the case of a metal airframe the star point can be the whole airframe, because of the low impedance of the metal airframe structures.)

**STP (Shielded Twisted Pair)**

STP is used in noisy environments where the shield around each of the wire pairs, plus an overall shield, protects against excessive electromagnetic interference. Contrast with UTP.

**Transient protection devices: see Lightning Arrester**

**UTP - (Unshielded Twisted Pair)**

A pair of wires that are twisted around each other to minimize interference. Contrast with STP.

## 36.9 Related documentation

DOCUMENT	DETAILS
DOC/DBK/001	<i>Acra KAM-500 Databook</i> , "Equipment Interface" chapter
DOC/HBK/002	Environmental Qualification Handbook (Acra KAM-500)
DOC/HBK/008	Environmental Qualification Handbook for Axon Products

## 36.10 References

1. Walt Kester, James Bryant, and Mike Byrne, "Grounding Data Converters and Solving the Mystery of 'AGND' and 'DGND'", Tutorial MT-031, Analog Devices, 2009. <https://www.analog.com/media/en/training-seminars/tutorials/MT-031.pdf>
2. "EMI, RFI, and Shielding Concepts", Tutorial MT-095, Analog Devices, 2009. <https://www.analog.com/media/en/training-seminars/tutorials/MT-095.pdf>
3. Steve Macatee, "Grounding and Shielding Audio Devices", RaneNote 151, Rane, 2002. <https://www.ranecommercial.com/legacy/note151.html>
4. "Electrical Grounding Architecture For Unmanned Spacecraft", NASA-HDBK-4001 NASA Technical Handbook, 1998. <https://s3vi.ndc.nasa.gov/ssri-kb/static/resources/NASA-HDBK-4001.pdf>
5. Bradley, Arthur T. and Hare, Richard J. "Effectiveness of Shield Termination Techniques Tested with TEM Cell and Bulk Current Injection", IEEE EMC 2009 Symposium, NASA Langley Research Centre, 2009. <https://ntrs.nasa.gov/citations/20090033805>
6. Keith Armstrong, "Terminating cable screens (shields)", EMCStandards.co.uk, The EMC Journal, Issue 82, 2009. <https://www.emcstandards.co.uk/terminating-cable-screens-shields>
7. Keith Armstrong, "EMC, systems & installations, 2000, Part 2, Installations", EMCStandards.co.uk, EMC Compliance Journal, 2000. <https://www.emcstandards.co.uk/emc-systems-installations-2000-part-2-insta>

This page is intentionally blank