



PacStar 431

Rugged Edge AI Processing Platform

Key Features

- NVIDIA IGX Thor AI processor with 14-core Arm CPU and 2560-core Blackwell GPU capable of up to 2070 FP4 TFLOPS of performance
- High-speed Ethernet ports for sensor ingest and network connectivity
 - (2) SFP28 ports (10/25 G)
 - (3) 1000BASE-T ports (1 G)
- Removable high-speed NVMe® storage
- Hardware root of trust, secure boot
- Extended temp, rugged design extensively tested under MIL-810/461
- Hot-swappable, snap-on battery connectors support continuous runtime
- KG-250X/XS compatible power output
- Small, but powerful: only 5.3 in x 7.1 in x 1.7 in and 2.7 lb

Applications

- Generative AI and large language model (LLM) processing workloads at tactical edge with high-speed sensor ingest and network connectivity
- Manned and autonomous systems performing real-time, multi-sensor data analytics and decision making

PacStar® 431 AI Server Module provides a modular embedded computing platform harnessing NVIDIA's high-performance IGX Thor GPU-accelerated artificial intelligence (AI) and edge processor technology. IGX Thor is the industrial-grade, long-lifecycle variant of the Jetson AGX Thor supercomputer and follow-on to IGX Orin™.

Packaged for deployment at the tactical edge and optimized for demanding real-time edge compute, AI workloads, and next-generation command and control. Ready to bring real-time sensor fusion, data inferencing and decision making to autonomous machines and operators, PacStar 431 comes ready with NVIDIA Enterprise Linux to host CUDA® libraries and NVIDIA® AI pre-trained models.

Delivering 7.5x more AI compute horsepower than NVIDIA IGX Orin, PacStar 431 integrates a 2560-core NVIDIA Blackwell GPU with a 14-core Arm® Neoverse®-V3AE CPU and 128 GB of high-speed memory. Together with network connectivity up to 25 Gbps, low-latency NVMe storage, and high-speed I/O, this robust compute node is designed to tackle complex, multi-sensor AI workloads in SWaP-constrained austere environments.

Like other PacStar 400-Series modules, PacStar 431 features a small form factor, snap-together design, compatible with other PacStar 400-Series servers, switches, routers, and gateways, as well as flexible packaging solutions, including briefcase style, transit case style, 19 inch rack mount, vehicle-mount, and backpack style transport options. The PacStar 400-Series ecosystem provides users with Commercial Off-the-Shelf (COTS) modular open system approach (MOSA) building blocks to create complete system solutions for the tactical edge, flexibly architected to scale for any application need.

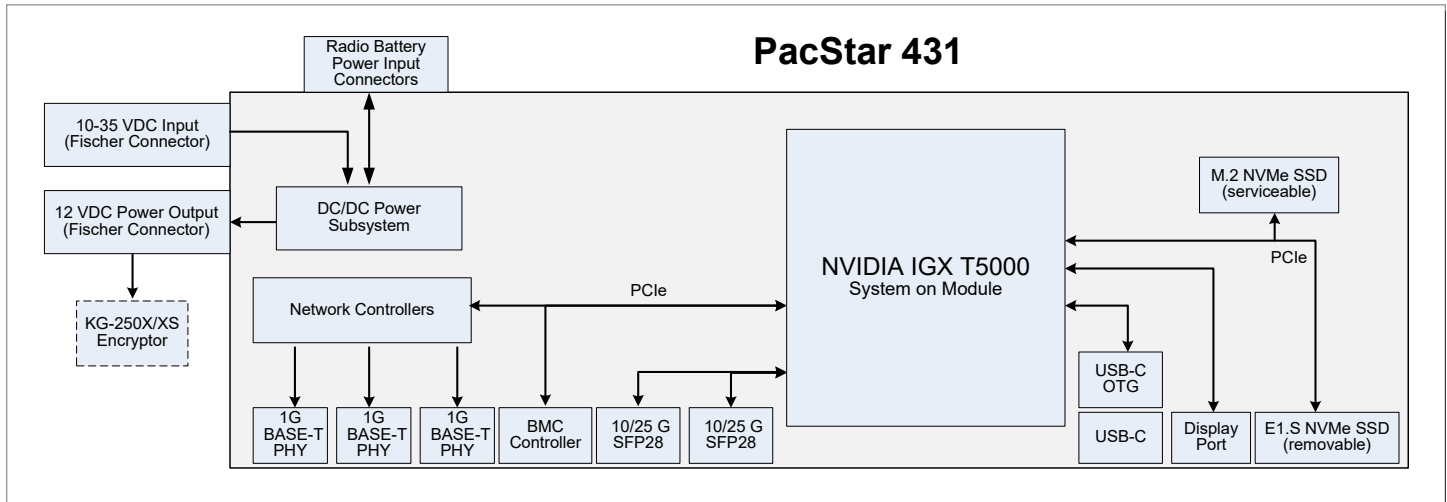

Figure 1: Product block diagram

Specifications

NVIDIA IGX Thor T5000 SoM

- Industrial-temp rated, long-lifecycle support
- 14-core Arm Neoverse-V3AE, 64-bit CPU
- 2560 CUDA-core Blackwell GPU
 - 96 Tensor cores, 5th gen
 - 3GPC with Multi-Instance GPU (MIG) hardware resource partitioning support
- 128GB LPDDR5X memory
 - 256-bit, 273 GBps
- Deep Learning Accelerators (NVDLA)
- Programmable Vision Accelerator (PVA)
- Dual video encoders/decoders
- Configurable power/performance - up to 2070 TFLOPS (FP4) and 1035 TFLOPS (FP8)
- Advanced security: secure boot, Arm TrustZone, hardware root of trust, crypto acceleration, disk/memory encryption

Interfaces

- Two (2) 10/25 G Ethernet (SFP28)
- Three (3) 1000BASE-T Ethernet (RJ-45)
- One (1) IPMI Management (RJ-45)
- One (1) USB 3.2
- One (1) USB 3.2 – OTG Debug
- One (1) DisplayPort (DP1.4a @ 8K60)

Data Storage

- One (1) internal serviceable NVMe boot drive (up to ~1 TB)
- One (1) removable NVMe SSD (up to ~8 TB) – contact sales for higher capacity / FIPS 140/SED options

Power Specifications

- Wide range DC input, 10-35 V
- World-wide AC power input (with adapter cable)
- Max power consumption (est): ~50-150 W (configurable and operating temperature dependent)
- Battery snap-together connectors for 1-2 each AN/PRC-152/148 snap on radio batteries; hot-swappable with ~2 hours runtime per battery
- Regulated clean 12 VDC output, 20 W (KG-250X/XS support)

Physical Specifications

- Dimensions (W x D x H): 5.3 in x 7.1 in x 1.7 in
- Weight (est): 2.7 lb
- Operating temp range: -40 to 60 °C
 - Under <75 W IGX Thor power profiles
- Extensive testing (pending) to MIL-STD-810/461

PacStar 431

